

IBC

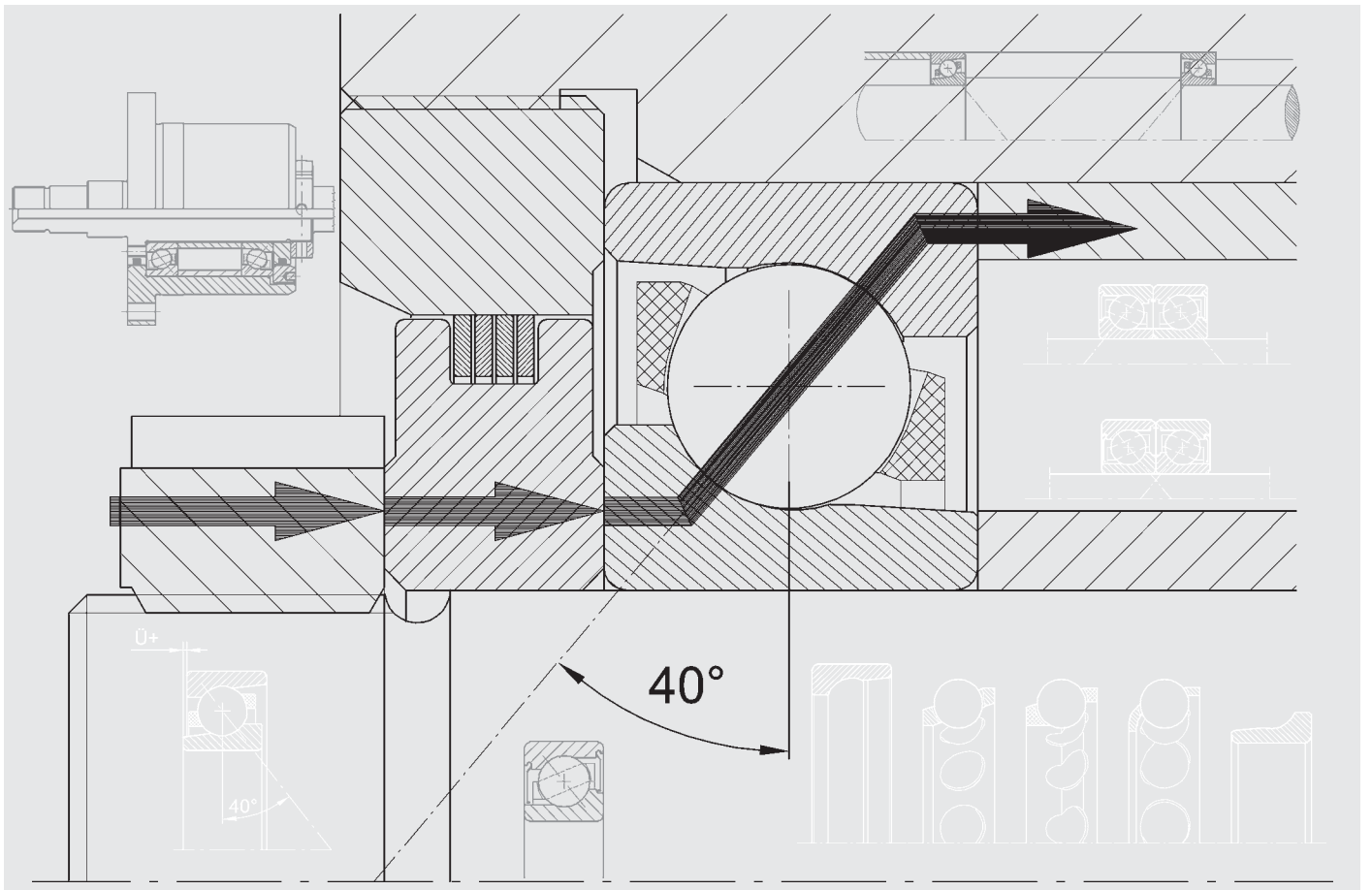

Angular Contact Ball Bearings 40°

TI-I-4044.0 / E

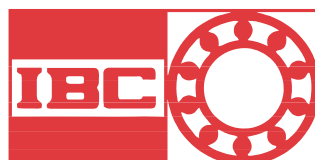



Headquarter of the IBC Wälzlager GmbH at the industrial area of Solms-Oberbiel



Location with Tradition

The headquarters in Solms-Oberbiel is centrally located in Germany close to the North/South and East/West highways which also provides for a central location in Europe. The international Airport Frankfurt approx. 80 km away serves as a worldwide link.



Flexible and Reliable

In the middle of 1996 we opened the central computer controlled high shelf warehouse with more than 2.000 pallet places. It is used for finished and semi-finished products as well as for large bearings.

This is in addition to our existing two-storage computer controlled service warehouse also with more than 2.500 storage places.

Both warehouse systems provide together with our distribution centre and communication network precise logistics and a worldwide unequaled reliability.



Central Computer Controlled High Shelf Warehouse – Middle 1996



Precise Logistics provide an unequaled worldwide reliability



New plant in Asslar



Precision with Future...

We are future orientated.
We have the creativity and vision to perform and provide.

This is our exact presentation to solutions with precision.



Single Row Angular Contact Ball Bearings of series BE with 40° contact angle

To meet all the different technical applications and operating conditions, accurate solutions are required. Only an extensive range of angular contact ball bearings fulfil the diversity of requirements such as high rotational speed and load carrying capacity, running accuracy, stiffness, as well as combined radial and axial load at low heat generation. Single Row 40° angular contact ball bearings can accommodate radial and axial loads in only one direction. (>See picture 44-101)

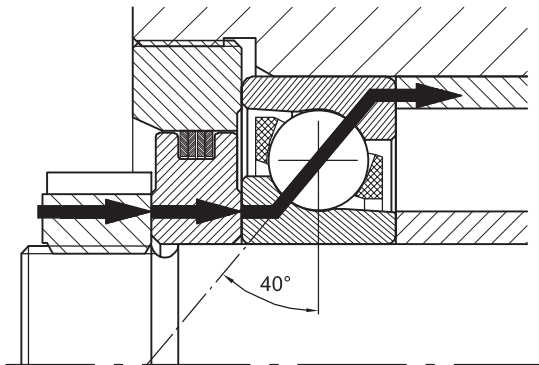

Load acting of 40° angular contact ball bearing

44-101

Also external radial loads are creating axial force within the bearing, which has to be compensated by a further bearing. Normally there are two angular contact ball bearings adjusted against each other.

There are typical fields of applications with combined radial and axial load within gears, gear motors, fans, compressors, screw compressors, ventilators, pumps, textile machines, printing machines, conveyors where shaft guidance free of clearance should be achieved. Distinguishing marks of IBC 40° angular contact ball bearings are quiet running, low friction, high rotational speed and a long lifespan. Especially usage in pumps or compressors are creating combined loads at high rotational speed often under unfavourable lubrication circumstances and heavy contamination.

IBC 40° angular contact ball bearings of BE series, with each one high and one low shoulder at the bearing rings are non-separable. In comparison to series B, load carrying capacity could have been increased due to larger balls.

The larger the axial load carrying capacity the larger the size of contact angle, which is including the conjunction line of both contact points between balls and raceways with the radial axis and from which the load is transferred from one raceway to the other.

Dimensions

The main dimensions of the IBC single row angular contact ball bearings are according to DIN 616, ISO 15 and DIN 628, part 1.

Series

IBC angular contact ball bearings are available in various designs. 70BE, 72BE, 73BE (> see picture 44-102). Further variations with other preloads are deliverable on request.

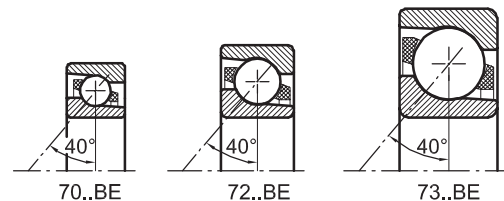

Comparison of cross sections of 40° Angular Contact Ball Bearings 44-102

Materials

Bearing rings and rolling elements are made of bearing steel 100Cr6 (1.3505) corresponding with SAE52100 and SUJ2.

Heat treatment

IBC angular contact ball bearings are dimensionally stable and can be used at operating temperatures of up to 130°C. In addition to higher values heat treatment for higher temperatures are available on request.

Cages

Depending on bearing design and size, various types of cages are deliverable.

P	Solid window cage PA6.6 Polyamide glass fibre reinforced, applicable up to 120 °C
M	Solid brass cage
J	Steel sheet
K	PEEK cage, glass fibre reinforced, applicable up to 200 °C, in case of high rotational speed up to max. 150 °C

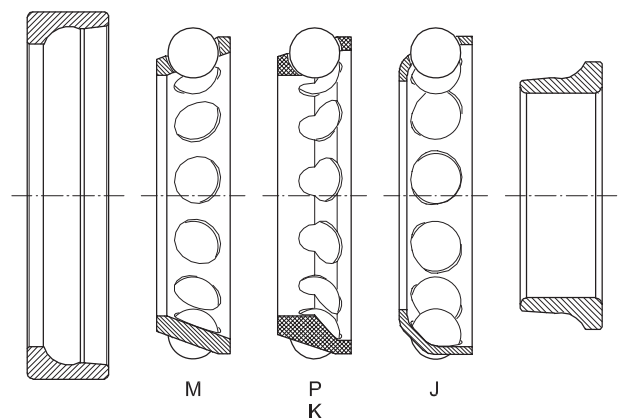

Cage designs

44-103

Remarks:

If the bearings are lubricated with oil, any additives contained in the oil may reduce the PA6.6 cage service life. At temperatures over 120°C steel cages, PEEK or brass cages should be used.

When using in ammonia surroundings such as freezing-apparatuses, bearings with brass cages are not suitable.

Sealed versions

IBC supplies types of angular contact ball bearings, which are sealed on both sides. The bearings are filled with lithium soap grease with mineral basic oil.

Bearings with special grease are recognized by suffix. IBC supplies also angular contact ball bearings with shields or seals on one or both sides. Bearings with basic sealing (2RSZ) can be used within a temperature range between -10°C up to +120°C. Sealing with fluor caoutchouc (Viton) is available on request.

Lubricated open bearings

Also open bearings could already be delivered with grease. Lubricants are recognized by suffix.

Hybrid bearings

Bearings with ceramic balls made of silicon nitride Si_3N_4 are applicable for current insulation. Due to low specific weight of ceramic balls and the resulting low centrifugal forces, an increase in rotational speed of up to 35% is possible in comparison to steel balls. Thus the dynamic load rating is kept and the static load rating is reduced to 70%.

Coated Bearings (Prefix AC)

ATCoat enables a bearing to be higher resistant against corrosion, wear and allows an increase of speed. This is caused by thin dense chromium coat. The special topographic surface also increases the ability of a bearing to withstand emergency situations. All these characteristics lead to use ATCoated IBC bearings under uncomfortable lubrication conditions.

These conditions are for example explained below:

- when it is impossible to use a lubricant,
- when it is only possible to use a low viscous lubricant, which cannot create a separating film,
- when movement is not a complete rotation, where the lubricant film will not remain,
- when the bearing is unloaded and the rolling elements start to slide,
- when in case of high acceleration or braking the rolling elements start so slide.

The ATCoat bearings are an opportunity to corrosion resistant bearings. The protective coat in connection with ceramic balls provides very good technical features (prefix ACC).

Designs

1) Single bearings

Single bearings are suitable where only one bearing per bearing location is used. These single bearings are positioned in a certain distance to each other.

A specially defined tightening torque via a locknut or a flange makes adjusting of preload or axial clearance. In case of such bearing arrangements single row angular contact ball bearings have to be adjusted against each other until the necessary preload or axial clearance is reached. The right adjustment of both single bearings is quite essential to guarantee the bearing's functionality. Otherwise lifespan would be reduced caused by higher friction loss and thus resulting higher operating temperatures. Even running noises or movement between balls and raceway may occur and thus complete load carrying capacity could not be fully used.

2) Universal bearings for mounting in pairs

Single row angular contact ball bearings for universal design are intended for mounting in pairs in T-arrangements (tandem) in such cases when load carrying capacity is not sufficient enough, respectively the bearing arrangements have to carry axial load in both directions (O- or X-arrangement). The universal bearings have a defined ground stick-out S at the lateral faces of the inner and outer ring. This enables adjustment without shims.

(> See Picture 44-104 a) with positive and b) with negative clearance, which means preload.)

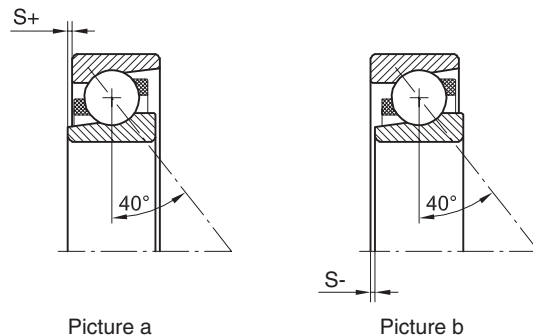

44-104

Axial clearance and preload classes are given in the table on page 5. The sequence of letters A, B, O, L, M signifies the amount of high axial play to medium preload.

The mentioned figures show the non-mounted bearing arrangements of two bearings without measuring load.

Universally ground bearings show the same protruding distance of inner to outer ring on both sides and therefore are applicable for any O-, X- or T-arrangements.

Arrangements

Accommodation of axial load in both directions enables O- and X-arrangement. Due to contact lines meeting in apexes outside of the two bearings, O-arrangement is more suitable for accommodation of tilting moments, considering that bearing sets in such arrangements result in a relatively rigid bearing arrangement. Comparing to O-arrangement, the contact lines of X-arrangement are converging within the two bearings.

Considering the above, the X-arrangement is less rigid. In case of main load in one direction bearings could be mounted in tandem arrangement. In case of occasional change of load direction a counter acting bearing would be necessary. (Please refer to column "radial clearance and preload".)

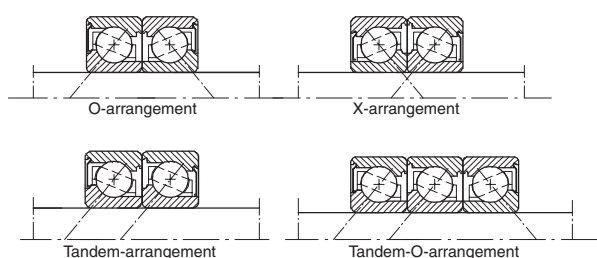

Bearing arrangements

44-105

Inclination

Misalignment should be avoided. According to arrangement at max. 2 angular minutes. Inclination is leading to a certain seizure, higher running noise and reduces lifetime.

Whereas X-arrangement is less delicate than O-arrangement.

Clearance and preload

Under appropriate operating conditions and reference speed, very low preload is optional to reach regular and free rolling of elements. Perfect rolling is granted with load distribution $F_a/F_r > 1$.

That means, in stationary (cold) conditions, bearings are used with minimum internal clearance as under operating conditions the inner rings are warming up more than the outer rings and thus clearance is becoming smaller, respectively preload is becoming larger.

Tight fits for shaft and housing are using further clearance. In case of high operating clearance, load capacity of the bearings is not completely used.

In case of unidirectional load in O- and X-arrangement, further considerations should be observed.

The counter bearings should not mainly be discharged temporary, as within the discharged bearing unfavourable sliding of balls may happen. This may influence the noise, lubricant film, load on cage and lifespan. Light preload or a clearance free solution should be chosen.

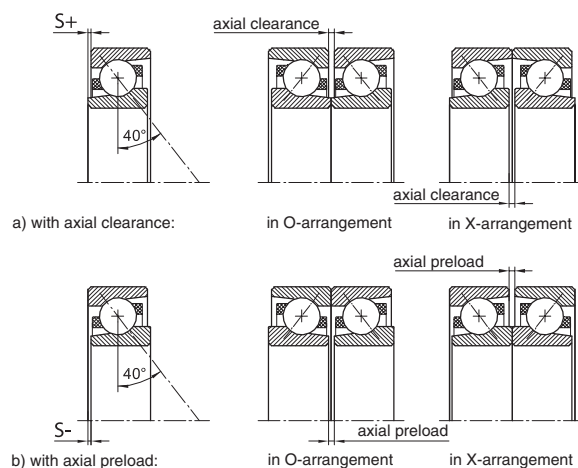

Bearing arrangements with axial clearance and axial preload

44-200

Bore diameter		Series	UA		UB		UO		UL		UM		UH	
over	incl.		max.	min.	max.	min.	max.	min.	min.	max.	min.	max.	min.	max.
			[µm]		[µm]		[µm]		[µm]		[µm]		[µm]	
10	– 18	72	31	23	19	11	6	–2	2	–6	–4	–12	–8	–16
		73	33	25	21	13	8	–4	4	–8	–6	–14	–10	–18
18	– 30	70	38	30	21	13	4	0	0	–4	–2	–10	–6	–14
		72	40	32	23	15	6	–2	2	–6	–4	–12	–8	–16
		73	42	34	25	17	8	–4	4	–8	–6	–14	–10	–18
30	– 50	70	47	39	25	17	4	0	0	–4	–2	–10	–6	–14
		72	49	41	27	19	6	–2	2	–6	–4	–12	–8	–16
		73	51	43	29	21	8	–4	4	–8	–6	–14	–10	–18
50	– 80	72	60	48	34	22	9	–3	3	–9	–6	–18	–12	–24
		73	62	50	36	24	11	–5	5	–11	–8	–20	–14	–26
		72	67	55	38	26	9	–3	3	–9	–6	–18	–12	–24
80	– 120	73	69	57	40	28	11	–5	5	–11	–8	–20	–14	–26
		72	73	61	41	29	9	–3	3	–9	–6	–18	–12	–24
120	– 180	73	75	63	43	31	11	–5	5	–11	–8	–20	–14	–26
		72	90	74	51	35	12	–4	4	–12	–8	–24	–16	–32
180	– 250	73	92	76	53	37	14	–6	6	–14	–10	–26	–18	–34

Axial clearance and preload of IBC 40° angular contact ball bearings (pair arrangements)

44-201

Fits for point and circumferential loads

Fits mainly influence the clearance or preload and thus the following information should be observed. First of all it has to be detected which rings accommodate rotating load und which point load. Rings with point load are less critical, as they are only lightly clamped on the counter part. In this way a certain area of the ring diameter is always loaded. The larger the shocks and load are, the stronger the fits should be. Scheme point load und circumferential load (> see picture 40-300).

Inner ring		Outer ring	
	Point load inner ring stands still load direction unchanged		Circumferential load outer ring rotating load direction unchanged
	Point load inner ring rotating load direction rotating with inner ring		Circumferential load outer ring stands still load direction rotating with inner ring
	Circumferential load inner ring stands still load direction rotating with outer ring		Point load outer ring rotating load direction rotating with outer ring
	Circumferential load inner ring rotating load direction unchanged		Point load outer ring stands still load direction unchanged

Point load and circumferential load

40-300

The light fits are used for lighter loads each up to $0.08 \cdot C$, the tighter for higher load ratio.

Strong fits and temperature drop between the inner and outer ring result in reduction of radial and axial clearance and has to be considered accordingly.

The fits should be adjusted according to the required preload when operating temperature is reached. For hollow shafts and thin-walled housings stronger fits should be taken.

Precision class	Inner ring	Outer ring	Shaft			Housing		
			PN, P6	P5	P4	PN, P6	P5	P4
Point load on IR circumferential load on AR	IR to be moved lightly, slide fit	OR tight fit	g6	g5	g4	M7	M6	M5
	IR not lightly moveable		h6	h5	h4			
Point load on AR circumferential load on IR	IR tight fit	OR slight fit	j6, k6	js5, k5	js4, k4	H7	H6	H5
		OR not to be moved lightly				J7	JS6	JS5
Undetermined load		OR is relatively tight				J7, K7	JS6, K6	JS5, K5

Fits for point and circumferential load

40-301

The factor for radial clearance is approximately $0.85 \times$ axial clearance.

Reduction of radial clearance by fits and operating conditions

The radial clearance is approximately reduced by the following equation:

$$S_{\text{reff}} = S_o - (S_{\text{int}} + S_T) \quad [\text{mm}] \quad [1.0]$$

S_{reff}	Effective radial operational clearance
S_o	Clearance before mounting
S_{int}	Reduced clearance due to interference
S_T	Reduced clearance due to temperature differences between inner and outer ring

After mounting the following clearance appears:

$$S_m = S_o - S_{\text{int}} \quad [1.1]$$

$$S_{\text{int}} = \text{Int}_i \cdot f_i + \text{Int}_o \cdot f_o \quad [\text{mm}] \quad [1.2]$$

Int_i	Interference inner ring
Int_o	Interference outer ring
f_i	Reduction factor inner ring
f_o	Reduction factor outer ring

Guidelines:

f_i	Solid shaft	0.8
f_o	Steel or cast iron housing	0.7
f_i	Hollow shaft	0.6
f_o	Light metal housing	0.5

f_i and f_o are depending on roughness and diameter of bearing rings, respectively the diameter of the hollow shaft. Due to restricted possibility of temperature reduction and small surface and frequent over-rolling of bearings elements, there is a temperature difference of $5 - 10 \text{ K}$ during operating. When working with cold or hot mediums this value will be changed accordingly.

$$S_T = \alpha \Delta_T d_m \quad [\text{mm}] \quad [1.3]$$

α	Expansion value of bearing steel $12 \cdot 10^{-6}/\text{K}$
Δ_T	Temperature difference inner and outer ring
d_m	Mean bearing diameter

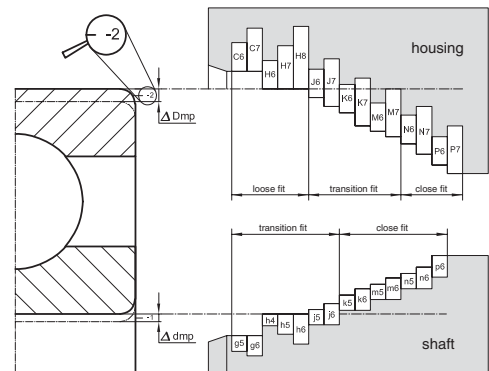

General fits

40-302

Tolerances of 40° Angular Contact Ball Bearings

	Inner ring [mm]	Precision	Ø 2,5	10	18	30	50	80	120	150	180	250
			to 10	18	30	50	80	120	150	180	250	315
Δ_{dmp}	Maximum deviation of the mean bore diameter from the nominal	PN	-8	-8	-10	-12	-15	-20	-25	-25	-30	-35
		P6	-7	-7	-8	-10	-12	-15	-18	-18	-22	-25
		P5	-5	-5	-6	-8	-9	-10	-13	-13	-15	-18
		P4	-4	-4	-5	-6	-7	-8	-10	-11	-12	-15
K_{ia}	Radial runout of assembled bearing inner ring	PN	10	10	13	15	20	25	30	30	40	50
		P6	6	7	8	10	10	13	18	18	20	25
		P5	4	4	4	5	5	6	8	8	10	13
		P4	2,5	2,5	3	4	4	5	6	6	8	-
S_d	Side face runout referring to bore of inner ring	P5	7	7	8	8	8	9	10	10	11	13
		P4	3	3	4	4	5	5	6	6	7	-
S_{ia}	Side face runout of the assembled bearing inner ring	P5	7	7	8	8	8	9	10	10	13	15
		P4	3	3	4	4	5	5	7	7	8	-
Δ_{Bs}	Deviation of single inner ring width	PN, P6	-120	-120	-120	-120	-150	-200	-250	-250	-300	350
		P5, P4	-40	-80	-100	-120	-150	-200	-250	-250	-300	350
		PN, P6, P5, P4	-250	-250	-250	-250	-250	-380	-380	-380	-500	-500
V_{Bs}	Ring width variation	P6	15	20	20	20	25	25	30	30	30	35
		P5	5	5	5	5	6	7	8	8	10	13
		P5	5	5	5	5	6	7	8	8	10	13
		P4	2.5	2.5	2.5	3	4	4	5	5	6	-

	Outer ring [mm]	Precision	Ø 18	30	50	80	120	150	180	250	315	400	500
			to 30	50	80	120	150	180	250	315	400	500	630
Δ_{Dmp}	Maximum deviation of mean outside diameter of nominal	PN	-9	-11	-13	-15	-18	-25	-30	-35	-40	-45	-50
		P6	-8	-9	-11	-13	-15	-18	-20	-25	-28	-33	-38
		P5	-6	-7	-9	-10	-11	-13	-15	-18	-20	-23	-28
		P4	-5	-6	-7	-8	-9	-10	-11	-13	-15	-18	-22
K_{ea}	Radial runout of assembled bearing outer ring	PN	15	20	25	35	40	45	50	60	70	80	100
		P6	9	10	13	18	20	23	25	30	35	-	-
		P5	6	7	8	10	11	13	15	18	20	-	-
		P4	4	5	5	6	7	8	10	11	13	-	-
S_D	Variation of inclination of outside cylindrical surface to outer ring side face	P5	8	8	8	9	10	10	11	13	13	-	-
		P4	4	4	4	5	5	5	7	8	10	-	-
S_{ea}	Side face runout referring to raceway of assembled bearing outer ring	P5	8	8	10	11	13	14	15	18	20	-	-
		P4	5	5	5	6	7	8	10	10	13	-	-

The width tolerances of the outer ring (ΔC_s , V_{C_s}) are according to those of the inner ring (ΔB_s , V_{B_s})

Values given in μm

The whole width tolerance of a bearing set is resulting out of the sum of single tolerances.

Tolerances

Additional to normal tolerances PN each series are also available in precision grade P6 and P5. Bearings with precision grade P4 are deliverable on request. P6.UA, P5.UA, P5.UL are standard versions.

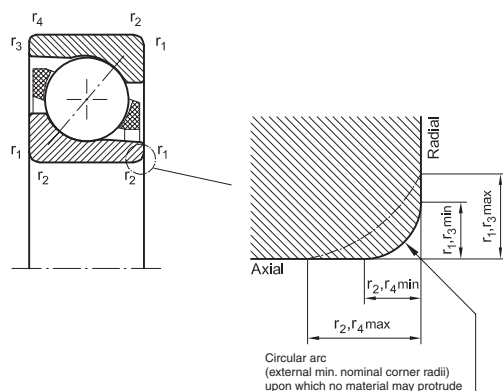

Nominal corner width r_{min}, r_{12}, r_{34} mm	Bore diameter d		Tolerance of corner width			
	over mm	incl.	Radial r_1, r_3		Axial r_2, r_4	
			min.	max.	min.	max.
0.2	-	-	0.2	0.5	0.2	0.8
0.3	-	40	0.3	0.6	0.3	1.0
0.6	-	40	0.6	1.0	0.6	2.0
	40	-	0.6	1.3	0.6	2.0
1.0	-	50	1.0	1.5	1.0	3.0
	50	-	1.0	1.9	1.0	3.0
1.1	-	120	1.1	2.0	1.1	3.5
	120	-	1.1	2.5	1.1	4.0
1.5	-	120	1.5	2.3	1.5	4.0
	120	-	1.5	3.0	1.5	5.0
2.0	-	80	2.0	3.0	2.0	4.5
	80	220	2.0	3.5	2.0	5.0
2.1	-	280	2.1	4.0	2.1	6.5
2.5	-	100	2.5	3.8	2.5	6.0
	100	280	2.5	4.5	2.5	6.0
3.0	-	280	3.0	5.0	3.0	8.0

Tolerances of corner dimensions according DIN 620, part 6

44-304

Table of corner dimensions

40-304

Tolerances of adjacent parts for 40° Angular Contact Ball Bearings

Form accuracy of shafts

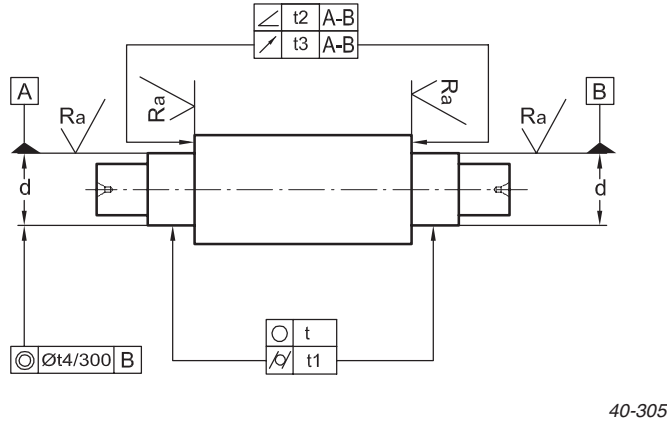

40-305

Form accuracy of housings

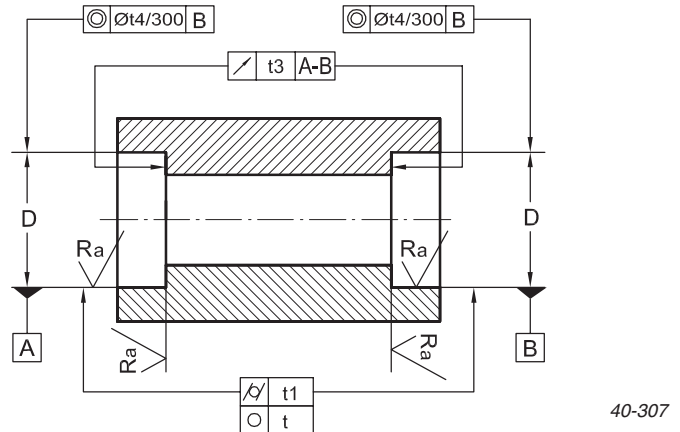

40-307

Feature	Tolerance symbol	Tolerance value	Admissible form tolerances Tolerance/Roughness grade Bearing tolerance classes			
			PN	P6	P5	P4
Roundness	\bigcirc	t	$\frac{IT5}{2}$	$\frac{IT4}{2}$	$\frac{IT3}{2}$	$\frac{IT2}{2}$
Cylindrical form	\bigcirc with slash	t1	$\frac{IT5}{2}$	$\frac{IT4}{2}$	$\frac{IT3}{2}$	$\frac{IT2}{2}$
Squareness	\sphericalangle	t2	-	-	-	$\frac{IT3}{2}$
Axial runout	\nearrow	t3	IT5	IT4	IT3	IT3
Concentricity	\odot	t4	IT6	IT6	IT5	IT4
Roughness R_a						
d ≤ 80 mm		-	N6	N5	N4	N4
d > 80 mm		-	N7	N6	N5	N5

Form accuracy of shafts

40-306

Feature	Tolerance symbol	Tolerance value	Admissible form tolerances, tolerance/roughness grade bearing tolerance classes			
			PN	P6	P5	P4
Roundness	\bigcirc	t	$\frac{IT5}{2}$	$\frac{IT4}{2}$	$\frac{IT3}{2}$	$\frac{IT2}{2}$
Cylindrical form	\bigcirc with slash	t1	$\frac{IT5}{2}$	$\frac{IT4}{2}$	$\frac{IT3}{2}$	$\frac{IT2}{2}$
Axial runout	\nearrow	t3	IT5	IT4	IT3	IT3
Concentricity	\odot	t4	IT7	IT6	IT5	IT4
Roughness R_a						
D ≤ 80 mm		-	N6	N6	N5	N5
80 < D ≤ 250		-	N7	N7	N6	N6
D < 250 mm		-	N7	N7	N7	N7

Form accuracy of housings

40-308

ISO main tolerances according to DIN 7151									
Diameter Nominal size		Tolerances							
More than	up to	IT0	IT1	IT2	IT3	IT4	IT5	IT6	IT7
mm	mm	μm							
6	10	0.6	1	1.5	2.5	4	6	9	15
10	18	0.8	1.2	2	3	5	8	11	28
18	30	1	1.5	2.5	4	6	9	13	21
30	50	1	1.5	2.5	4	7	11	16	25
50	80	1.2	2	3	5	8	13	19	30
80	120	1.5	2.5	4	6	10	15	22	35
120	180	2	3.5	5	8	12	18	25	40
180	250	3	4.5	7	10	14	20	29	46
250	315	4	6	8	12	16	23	32	52
315	400	5	7	9	13	18	25	36	57
400	500	6	8	10	15	20	27	40	63

Main tolerances according DIN 7151

40-309

Design of adjacent parts

The accuracy of adjacent parts are to be adjusted according to the requirements of application and thereupon the precision of the bearings (> see picture 44-305, picture 44-307). The bearings with their relatively slim rings will adjust themselves to form deviations of shafts and housings. The chosen fits are depending on the rotational condition of bearing rings in relation to load direction (> see picture 40-300, 40-301, 40-302, page 6).

Roughness grade	Roughness grade R_a μm
N3	0.1
N4	0.2
N5	0.4
N6	0.8
N7	1.6

Roughness R_a of axial shoulder of spindle, within the housing and of annular spacer:
N6 = 0.8 μm

Roughness grades

40-310

Bearing design

Dimensioning of bearings

According to DIN ISO 281 the nominal lifetime L_{10} is resulting out of the ratio between equivalent dynamical stress P to dynamical load rating C :

(L_{10} means that 90% of the bearings will attain this lifetime, 10% may fail)

$$L_{10} = \left(\frac{C}{P}\right)^3 \cdot \frac{10^6}{60 \cdot n} \quad [\text{h}] \quad [2.0]$$

Rotational speed n [min^{-1}]

Equivalent dynamical bearing stress P [N]

When mounting as single bearing or two single bearings in T-arrangement (tandem):

$$P = F_r \quad \text{if } F_a/F_r < 1.14 \quad [2.1]$$

$$P = 0.35 F_r + 0.57 F_a \quad \text{if } F_a/F_r > 1.14 \quad [2.2]$$

Dynamical load capacity C of two single bearings in T-arrangement (tandem) is: $C_{\text{single bearing}} \times 1.62$.

Determining of axial load accommodated by single bearings in T-arrangement (tandem)

Radial forces are producing an axial component; axial load has to be determined according to the already mentioned lifetime calculation (> see picture 44-400). (These equations are only valid under operating conditions without any clearance or preload.)

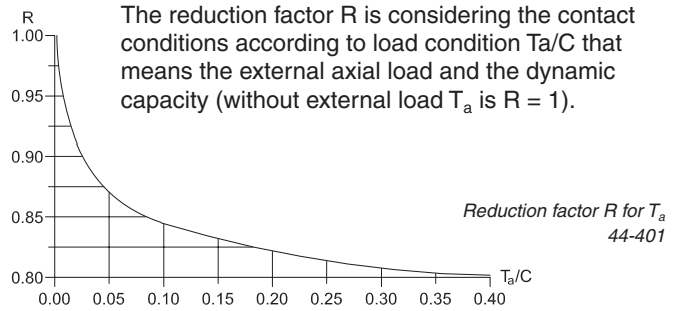

Bearing arrangements in O- or X-arrangement:

$$P = F_r + 0.55 F_a \quad \text{if } F_a/F_r < 1.14 \quad [2.3]$$

$$P = 0.57 F_r + 0.93 F_a \quad \text{if } F_a/F_r > 1.14 \quad [2.4]$$

(F_a and F_r affect the bearing pair)

Extended lifetime calculation L_{na}

In the so called extended lifetime calculation L_{na} depends on a variety of influences and safety requirements e. g. the modified materials, lubrication conditions, the cleanliness etc. in the modified lubricating gap the lubricant additives and the bearing type.

$$L_{na} = a_1 a_2 a_3 L_{10} \quad [\text{h}] \quad [2.5]$$

$$\begin{aligned} a_1 & \text{ life adjustment factor} \\ a_2 & \text{ factor for material } a_2 = a_{2b} \cdot a_{2s} \cdot a_{2w} \\ a_3 & \text{ factor for operating conditions} \end{aligned} \quad [2.6]$$

Bearing arrangement	Load condition	Axial force F_{aA}	Axial force F_{aB}
O-arrangement 	case A1 $F_{rA} \geq F_{rB}$ $T_a \geq 0$	$F_{aA} = R \times F_{rA}$	$F_{aB} = F_{aA} + T_a$
	case A2 $F_{rA} < F_{rB}$ $T_a \geq R \times (F_{rB} - F_{rA})$	$F_{aA} = R \times F_{rA}$	$F_{aB} = F_{aA} + T_a$
	case A3 $F_{rA} < F_{rB}$ $T_a < R \times (F_{rB} - F_{rA})$	$F_{aA} = F_{aB} - T_a$	$F_{aB} = R \times F_{rB}$
X-arrangement 	case B1 $F_{rA} \leq F_{rB}$ $T_a \geq 0$	$F_{aA} = F_{aB} + T_a$	$F_{aB} = R \times F_{rB}$
	case B2 $F_{rA} > F_{rB}$ $T_a \geq R \times (F_{rA} - F_{rB})$	$F_{aA} = F_{aB} + T_a$	$F_{aB} = R \times F_{rB}$
	case B3 $F_{rA} > F_{rB}$ $T_a \geq R \times (F_{rA} - F_{rB})$	$F_{aA} = R \times F_{rA}$	$F_{aB} = F_{aA} - T_a$

Axial forces with two angular contact ball bearings in X-, O- or in T-arrangement

44-400

Life adjustment factor

Reliability factor a_1

Reliability factor %	L_{na}	a_1
90	L_{10a}	1
95	L_{5a}	0.62
96	L_{4a}	0.53
97	L_{3a}	0.44
98	L_{2a}	0.33
99	L_{1a}	0.21

Life adjustment factors of material a_2

When using high quality bearing steel like 100Cr6 (1.3505) lifetime factor a_2 permits value 1. Surface treatment, heat stabilisation of steel, the use of ceramic balls (silicon nitride) may change the life adjustment factor a_2 . Extension by single factors a_{2b} , a_{2s} and a_{2w} is therefore recommendable.

$$a_2 = a_{2b} a_{2s} a_{2w} \quad [2.6]$$

Material factor a_2

Ring material	a_{2b}	heat stabilisation	a_{2s}	rolling element material	a_{2w}
100Cr6	1	150 °C	1	100Cr6	1
Uncoated	1	200 °C	0.75	Si_3N_4 -balls	2
IR ATCoat	1.25	250 °C	0.45		
AR ATCoat	1.2				
IR + AR ATCoat	1.5				

Life adjustment factor a_3

The attainable life depends on a variety of influences e.g. operating conditions, correct lubrication considering rotational speed and temperature, cleanliness in the lubrication gap or foreign particles.

Operating factor a_3 , is consisting of steel temperature factor a_{3ts} (so far it has not yet been calculated together with heat factor a_{2s} , then $a_{3ts} = 1$ up to 150°C) and the factor a_{3vi} , which is considering the operating temperature and the contamination.

$$a_3 = a_{3ts} \cdot a_{3vi} \quad [2.7]$$

a_{3ts} steel temperature factor (up to 150°C = 1)
 a_{3vi} viscosity factor

Further on lifetime of grease should be checked with bearing lifetime.

Calculation of life adjustment factor a_{3vi} in picture 40-503 via viscosity ratio κ

First of all the rated viscosity v_1 has to be determined, which is depending on rotational speed and the medium bearing diameter, see diagram picture 40-501, and the real viscosity v at operating temperature, see diagram picture 40-502. These factors have to be put in a ratio to result in κ -value. $\kappa = v/v_1$.

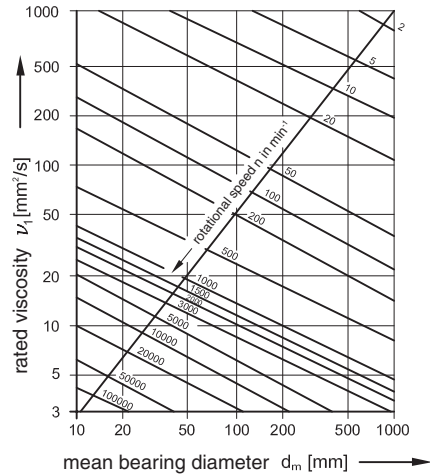

Required kinematics viscosity v_1

40-501

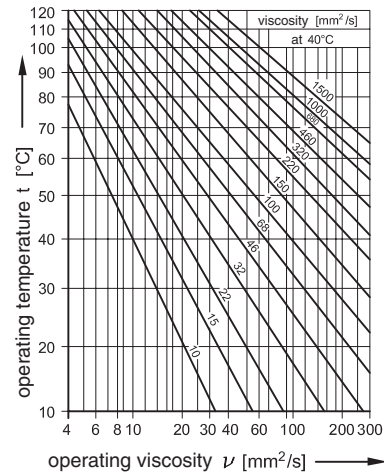

Viscosity at operating temperature for mineral oils

400-502

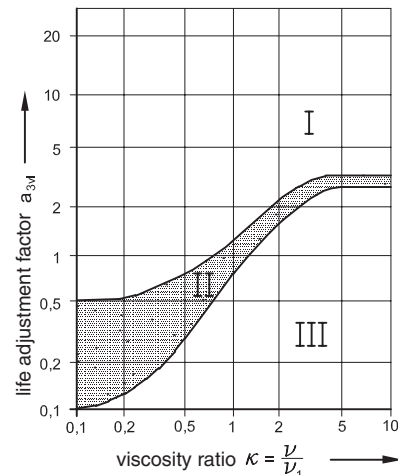

Diagram with different zones for κ and cleanliness

40-503

When using lubricants with a density that deviates from $\varphi = 0.9 \text{ g/cm}^3$ (mineral oil) κ has to be corrected by multiplying $\varphi / 0.9 \text{ g/cm}^3$ with the density ratio (especially in case of high temperature grease).

The ratio κ is required for locating the life adjustment factor a_{3vi} via spread zones in diagram 40-503. The spread curve II is showing normal operating conditions and normal cleanliness of lubricant. Higher value within the spread zone of curve could be reached by using adequate additives within the range $\kappa < 1$. If adequate quantities of an appropriate grease are used within the range $\kappa < 1$ higher values can be reached within the spreading of the curve. Special additives such as solid additives, polar property improves, and polymers reduce wear corrosion and enhance adhesion of lubricants in lubrication gap.

Low stress and high cleanliness together with suitable additives permit κ -values > 1 and even a_{3vi} -factors within range I. a_3 -values < 1 should be applied when viscosity of lubricants on mineral oil basis at operating temperatures of ball bearings equates $< 13 \text{ mm}^2/\text{s}$ and when the rotational speed value $n \cdot d_m < 10\,000 \text{ mm}/\text{min}$ thereupon is relatively small.

Cleanliness factor of lubrication gap regarding size of a_{3vi} value

In ratio with the bearing size, only particles with a hardness $> 50 \text{ HRC}$ have to be taken into account. The necessary oil cleanliness class ISO 4406 is an objectively measurable level of the contamination of a lubricant and ISO 4572 defines the filtration ratio, for example filtration ratio $\beta_6 > 75$ means that only one of 75 particles passes through the filter. There are 5 oil cleanliness grades with corresponding filtration ratio. It should be observed that filters larger than $\beta_{25} > 75$ are not applicable due to general life expectancy. In case of special requirements regarding accuracy of precision spindles a dust particle of $5 \mu\text{m}$ and hardness of $> 50 \text{ HRC}$ is far too much for such special applications. In that case work should be done under highest purity aspects.

For possible a_{3vi} -values see picture 40-503:

- > 1 utmost conditions: no particles, highest oil cleanliness grade
- 0.8 high cleanliness of bearings with shield and sealing, medium oil restrain values
- 0.1–0.5 open bearings with standard grease, where contamination by oil and humidity may penetrate into the bearing or non-filtered oil is used.

Lubricant service life

High operating temperatures over 70°C , due to self-heating or caused by high external temperatures may affect the lubricant lifetime and thereupon the whole bearing lifetime. Bearing lifetime and lubricant lifetime should be compared. See diagram picture 40-504, 40-505, 40-506.

Attainable lubricant lifetime according to diagram picture 40-506 is reduced together with the lubricant temperature value a_{3f} according to picture 40-504. Further lubricant lifetime factors are resulting in those factors mentioned on page 12 [2.14] and further on by air flow through the bearing of 0.1–0.7. In comparison with L_{nbearing} and L_{hgrease} re-lubrication is appropriate.

This is depending on the distance between lubricant operating temperature (bearing temperature at the inner ring t_b) to the max. allowed grease temperature limit t_{limit} .

Reduction of grease lifetime may happen from 70°C ; $a_t = 1$ i.e. when using lithium soap based grease on mineral oil base; with synthetic oils, considerable differences are possible.

In case of lasting stress at temperatures permitted only for short terms $a_t = 2$, grease lifetime will be reduced considerably.

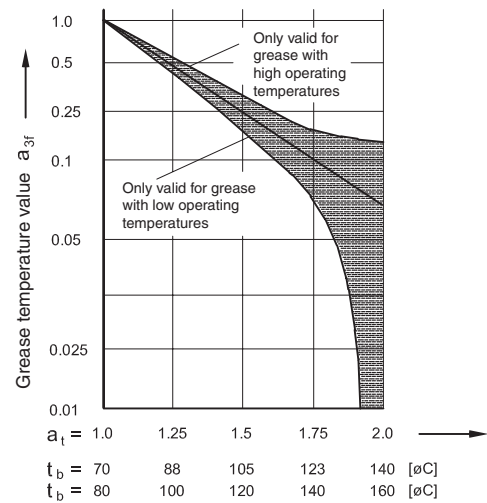

Grease life time

40-504

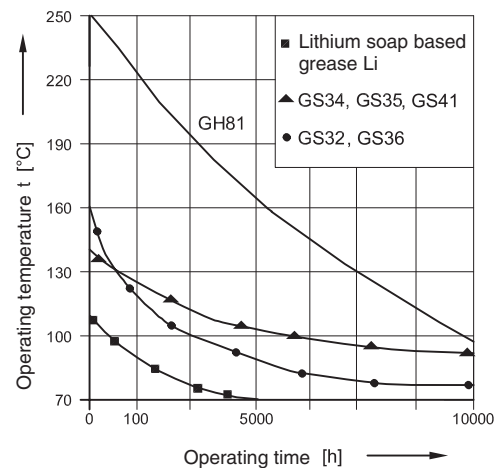

Grease service life at certain temperatures

40-505

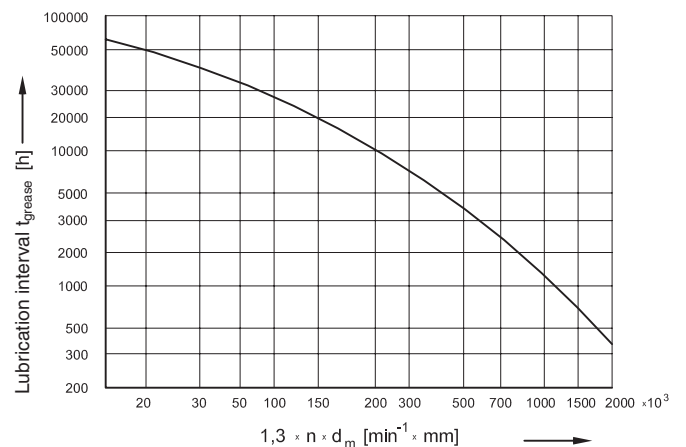

Lubrication intervals

40-506

Equivalent static bearing load P_o

For single bearings and tandem bearings:

$$P_o = 0.5 F_r + 0.26 F_a \quad [2.8]$$

($P_o < F_r$ calculated with $P_o = F_r$)

For bearing pairs in O- and X-arrangement:

$$P_o = F_r + 0.52 F_a \quad [2.9]$$

Static load ratings for two matched bearings:

$$C_o = 2 C_{o \text{ single bearing}} \quad [2.10]$$

$$\text{Static safety factor: } s_o = C_o/P_o \quad [2.11]$$

The requirements are depending on the requested quiet running and shock load.

Usual values for s_o : 0.5 ... 2

Reference rotational speed n_r

Load and lubrication conditions are defined in ISO 15312. The reference speed for oil and grease are mentioned therein referring to a steady state temperature of 70°C.

At a constant 5% radial load of static load rating C_o , at an ambient temperature of 20°C is taken as a basis for oil lubrication with mineral oil without EP additives, kinematic viscosity 12 mm²/s (ISO VG 32) with oil level reaching up to 30% of the bottom rolling element or grease lubrication with lithium soap and mineral base oil of 100–200 mm²/sec (ISO VG 150) at a temperature of 40°C with a filling grade of 30% free space within the bearing.

When using grease a reference temperature of 70°C can be reached after 20 h of grease distribution.

For bearings with rotating outer ring these values may be reduced under certain circumstances. Reference speed values are no speed limits. These figures only state that a temperature level of 70°C can be reached for single bearings under the above-mentioned load and lubrication conditions. For duplex bearings the rotational speed is reduced by 20% for normal internal bearing clearance. Compared with polyamide cages the rotational speed for steel and brass cages are reduced by 6%.

If no reference speed could be determined such as for sealed bearings, the limiting speed values of rubbing seals are indicated.

Depending on load ratio C/P the following speed characteristic values are suitable:

C/P	Speed ratio $d_m \times n$ [mm/min]
15	500 000
8	400 000
4	300 000

Determination of permissible operating speed n_{perm} depending on load and oil viscosity

As reference speed n_r is only defined for a special percentage load ratio under certain lubrication conditions, the admissible operational speed n_{perm} for other load and lubrication conditions has to be determined with the corresponding coefficients.

For reference values for load depending value f_p and viscosity factor f_v for oil lubrication please refer to diagram picture 44-507.

$$n_{perm} = f_p f_v n_r \quad [2.12]$$

In case of grease lubrication two values are obtained for f_v and put into proportion to each other.

$$n_{perm} = \frac{f_p f_v \text{ basic oil actual}}{f_v \text{ basic oil ISO VG 150}} n_r \quad [2.13]$$

Further reduction factors: [2.14]

Vertical shaft:	0.8
Rotating outer ring:	0.6
Shock load, vibrations:	0.4 ... 0.9

Rotational speed higher than reference speed

Due to heat dissipation by oil lubrication, air or liquid cooling of inner and outer rings, higher rotational speed can be obtained.

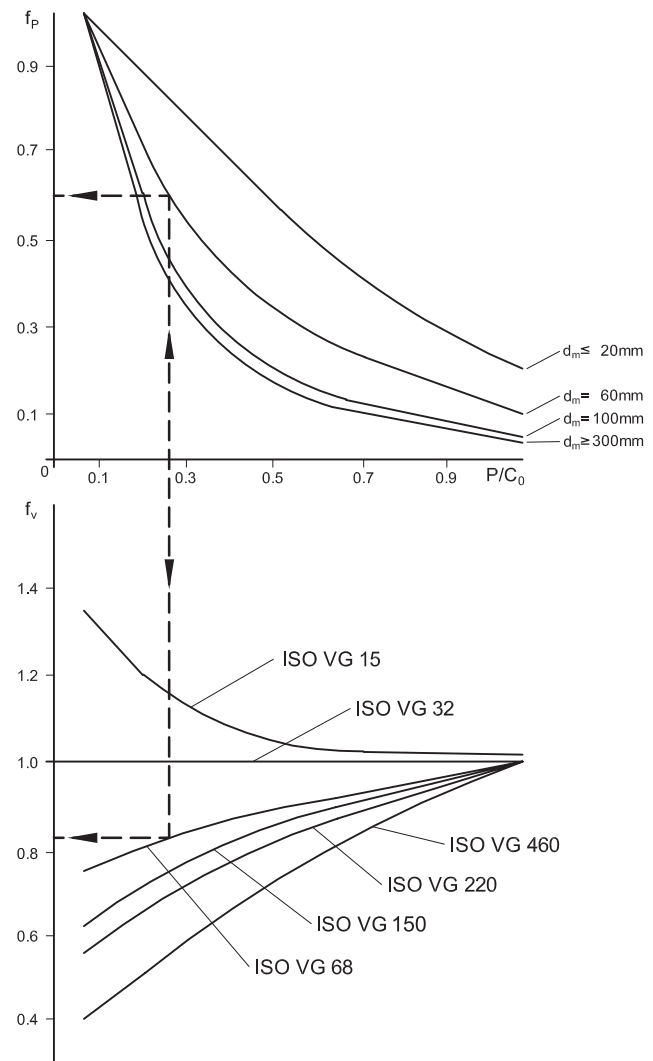

Correction factors for f_p and f_v

picture 44-507

Minimum load

Especially in case of high-speed bearings a minimum load should be designated to avoid sliding of rolling elements. Should the weight of the supported parts not be sufficient, corresponding loads could be applied by spring preloading. For single bearings and tandem arrangements a minimum axial load $F_{a\ min}$ and for bearing arrangements in O- and X-arrangement a minimum radial load $F_{r\ min}$ should be applied.

$$F_{a\ min} = k_a C_o d_m^2 n^2 10^{-13} \quad [2.14]$$

$$F_{r\ min} = k_r (n v)^{\frac{2}{3}} d_m^2 10^{-6} \quad [2.15]$$

$F_{a\ min}$ minimum axial load [N]
 $F_{r\ min}$ minimum radial load [N]
 k_a minimum axial load factor for
 series 72 = 1.4;
 series 73 = 1.6

k_r minimal radial load factor for
 series 72 = 95;
 series 73 = 100
 C_o static load [N]
 v base oil viscosity at operating temperature [mm²/s]
 n speed [min⁻¹]
 d_m mean bearing diameter [mm]

In case of high speed it has to be taken into consideration that higher speed means that because of centrifugal forces the balls of **single spring preloaded bearings** at the outer ring will be pressed to the centre of the raceway and those at the inner ring will be pressed up to the bord.

To keep the contact angle of 40° of spring preloaded single bearings constant at the inner and outer ring, the following minimum spring preload has to be applied:

$$F_{spring} = 25 C_o^2 n_{max}^2 10^{-15} [N] \quad [2.16]$$

Designation system 40° Angular Contact Ball Bearings

CB 70 05 . BE P . P6 . DBA
 72 06 . BE K . P5 . UL
 73 05 . BE P . 2RSZ . P5 . UO
 72 05 . BE J . UA
 73 07 . BE M . P6 . UA
 ACC- 73 08 . BE M . P5 . UO . A15.GH62

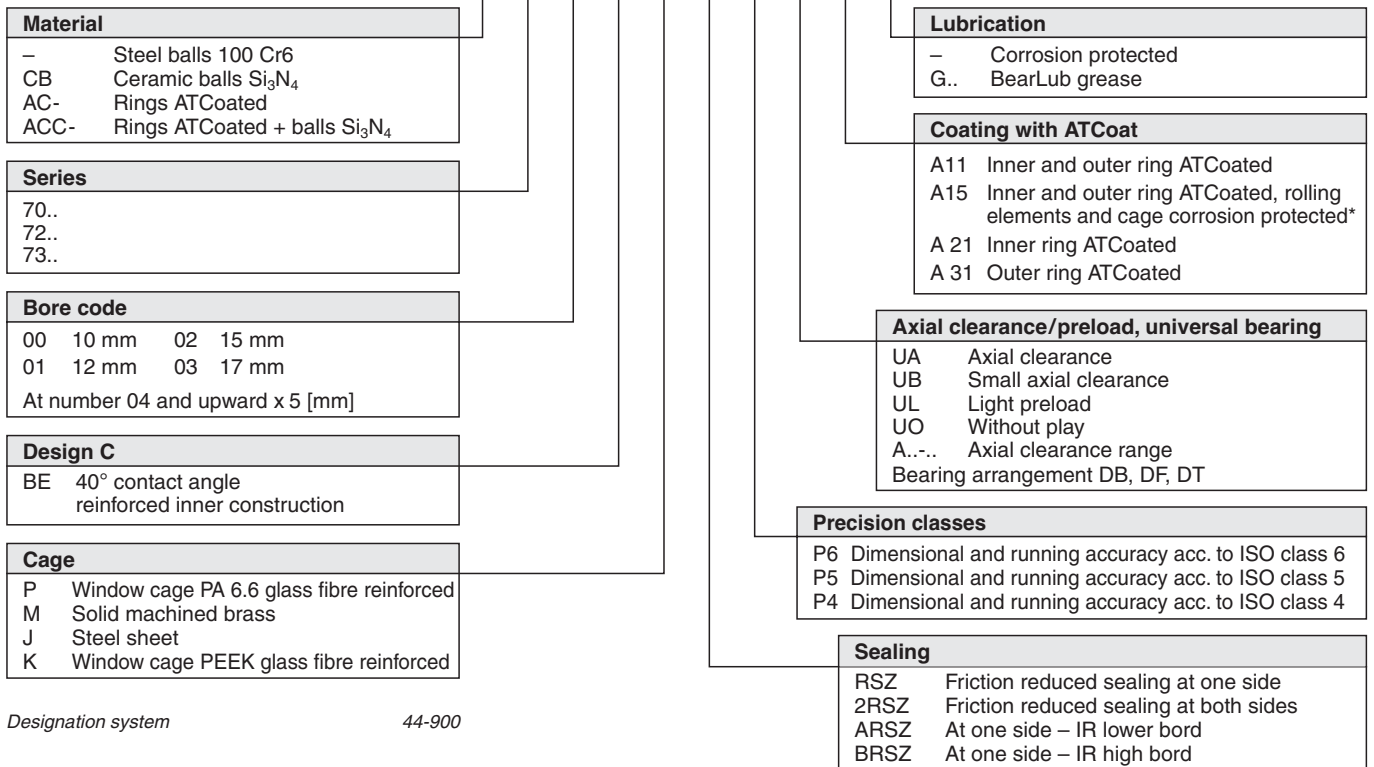

Designation system 44-900

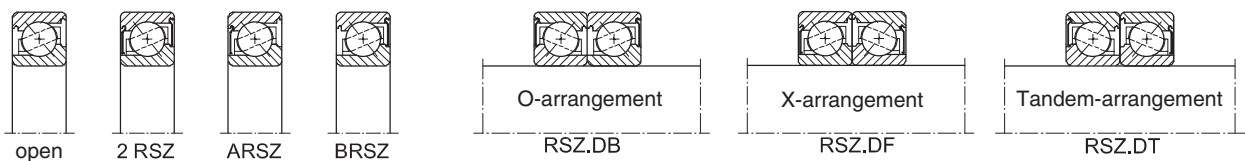

Open, sealed 40° angular contact ball bearings as single and matched bearing sets
 44-106

*Corrosion protection depending on application, for further information please refer to main catalogue

70..BE
CB 70..BE
72..BE
CB 72..BE
73..BE
CB 73..BE

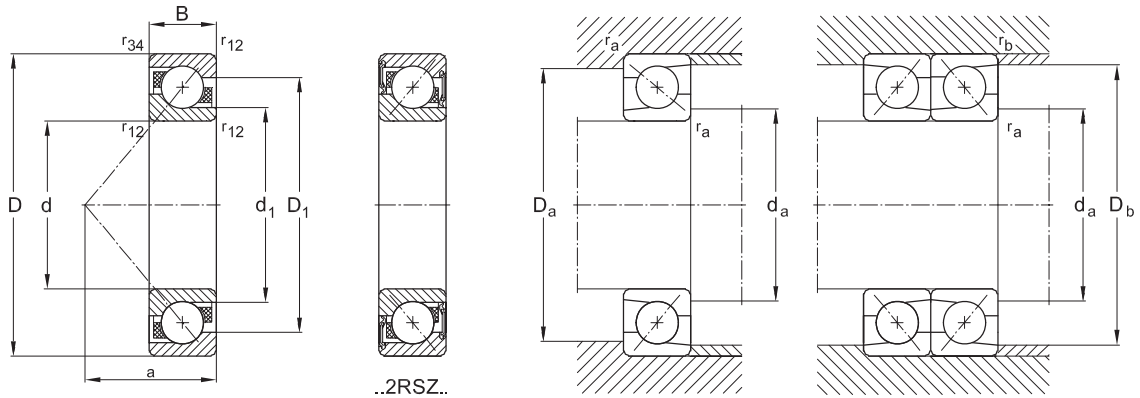

44-604

Primary dimensions			Basic designation	Basic load ratings		Fatigue load limit	Reference speed	Weight
d	D mm	B		dyn. C	stat. C ₀			
10	30	9	7200.BE	7 700	3 700	140	30 200	0.030
12	32	10	7201.BE	8 300	4 100	160	28 000	0.036
12	37	12	7301.BE	12 900	6 500	210	25 900	0.060
15	35	11	7202.BE	9 600	5 100	205	25 900	0.045
15	42	13	7302.BE	16 600	9 600	280	21 600	0.083
17	40	12	7203.BE	11 800	6 500	250	21 600	0.065
17	47	14	7303.BE	19 000	10 900	360	19 400	0.110
20	47	14	7204.BE	15 700	8 900	360	18 300	0.110
20	52	15	7304.BE	22 200	13 600	430	16 200	0.140
25	47	12	7005.BE	14 800	9 300	385	18 900	0.074
25	52	15	7205.BE	17 400	10 900	430	16 200	0.130
25	62	17	7305.BE	30 900	19 500	660	14 000	0.230
30	55	13	7006.BE	20 600	13 000	520	15 600	0.110
30	62	16	7206.BE	24 200	15 600	660	12 900	0.200
30	72	19	7306.BE	37 700	25 200	900	11 800	0.340
35	62	14	7007.BE	27 100	17 500	700	14 200	0.150
35	72	17	7207.BE	31 900	21 200	880	11 800	0.280
35	80	21	7307.BE	46 000	31 900	1 150	10 800	0.450
40	68	15	7008.BE	32 100	22 000	880	12 400	0.180
40	80	18	7208.BE	37 800	26 600	1 100	10 200	0.370
40	90	23	7308.BE	57 800	40 500	1 350	9 700	0.630
45	75	16	7009.BE	35 700	24 500	980	11 300	0.230
45	85	19	7209.BE	42 000	29 800	1 250	9 700	0.420
45	100	25	7309.BE	69 600	50 400	1 750	8 600	0.850
50	80	16	7010.BE	37 000	27 500	1 100	10 200	0.250
50	90	20	7210.BE	43 500	33 000	1 350	8 600	0.470
50	110	27	7310.BE	81 500	55 500	2 200	7 500	1.100
55	100	21	7211.BE	55 000	41 500	1 650	8 100	0.620
55	120	29	7311.BE	91 000	71 000	2 550	7 000	1.400
60	110	22	7212.BE	66 000	51 000	2 150	7 300	0.800
60	130	31	7312.BE	104 000	82 500	3 200	6 400	1.750

- Bearings with brass cage M have 5% less capacity due to inner construction.
- Static capacity C₀ of hybribe bearings CB = 0.7 C₀ of bearings with steel balls.

70..BE
CB 70..BE
72..BE
CB 72..BE
73..BE
CB 73..BE

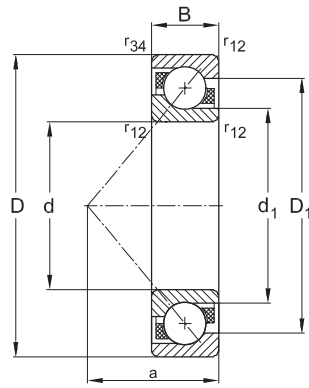

..2RSZ..

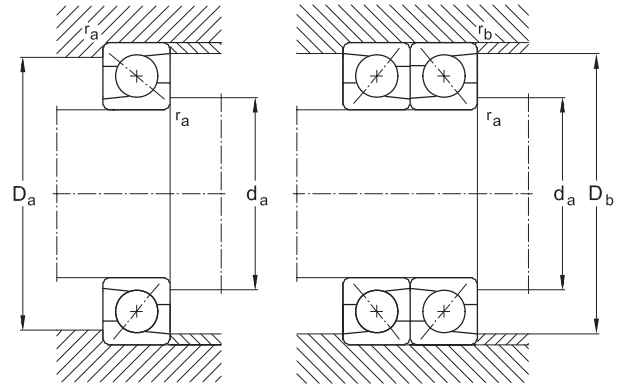

44-604

Basic designation	Dimensions					Abutment and fillet dimensions				
	a	d ₁	D ₁ mm	r _{12_min}	r _{34_min}	d _{a_min}	D _{a_max}	D _{b_max} mm	r _{a_max}	r _{b_max}
7200.BE	13	18.2	23.1	0.6	0.3	15.0	25.0	27.0	0.6	0.3
7201.BE	14	20.2	25.1	0.6	0.3	16.2	27.8	29.0	0.6	0.3
7301.BE	16	21.8	28.3	1.0	0.6	17.6	31.4	32.8	1.0	0.6
7202.BE	16	22.2	28.0	0.6	0.3	19.2	30.0	32.0	0.6	0.3
7302.BE	18	26.0	32.6	1.0	0.6	20.6	36.4	37.8	1.0	0.6
7203.BE	18	25.9	31.9	0.6	0.6	21.2	35.0	35.0	0.6	0.3
7303.BE	20	28.7	36.2	1.0	1.0	22.6	41.4	42.0	1.0	0.6
7204.BE	21	30.7	37.2	1.0	0.6	26.0	41.0	42.4	1.0	0.6
7304.BE	23	32.9	41.0	1.1	1.0	27.0	45.0	47.8	1.0	0.6
7005.BE	21.5	31.4	40.4	0.6	0.3	30.0	42.0	45.0	0.6	0.3
7205.BE	24	35.7	42.2	1.0	0.6	31.0	46.0	48.2	1.0	0.6
7305.BE	27	39.4	48.9	1.1	1.0	32.0	55.0	57.8	1.0	0.6
7006.BE	25	37.2	46.9	0.6	0.3	36.0	49.0	53.0	0.6	0.3
7206.BE	27	42.3	50.8	1.1	0.6	36.0	56.0	57.4	1.0	0.6
7306.BE	31	46.2	57.3	1.1	1.0	37.0	65.0	67.8	1.0	0.6
7007.BE	29	43.4	53.3	0.6	0.3	41.0	56.0	60.0	0.6	0.3
7207.BE	31	49.3	59.0	1.1	0.6	42.0	65.0	67.8	1.0	0.6
7307.BE	35	52.4	64.2	1.5	1.0	44.0	71.0	74.4	1.5	1.0
7008.BE	32	49.2	58.8	0.6	0.3	46.0	62.0	66.0	0.6	0.3
7208.BE	34	55.9	66.3	1.1	0.6	47.0	73.0	75.8	1.0	0.6
7308.BE	39	59.4	72.4	1.5	1.0	49.0	81.0	84.4	1.5	1.0
7009.BE	35	53.2	65.3	0.6	0.3	51.0	69.0	73.0	0.6	0.3
7209.BE	37	60.5	70.9	1.1	0.6	52.0	78.0	80.8	1.0	0.6
7309.BE	43	66.3	80.7	1.5	1.0	54.0	91.0	94.4	1.5	1.0
7010.BE	38	57.6	70.3	1.0	0.6	56.0	74.0	78.0	0.6	0.3
7210.BE	39	65.5	75.9	1.5	1.0	57.0	83.0	85.8	1.0	0.6
7310.BE	47	73.5	89.7	2.0	1.0	60.0	100.0	104.0	1.5	1.0
7211.BE	43	72.4	84.1	1.5	1.0	64.0	91.0	94.0	1.5	1.0
7311.BE	51	80.0	97.6	2.0	1.0	65.0	110.0	114.0	2.0	1.0
7212.BE	47	79.3	92.5	1.5	1.0	69.0	101.0	104.0	1.5	1.0
7312.BE	55	87.0	106.0	2.1	1.1	72.0	118.0	123.0	2.0	1.0

70..BE
CB 70..BE
72..BE
CB 72..BE
73..BE
CB 73..BE

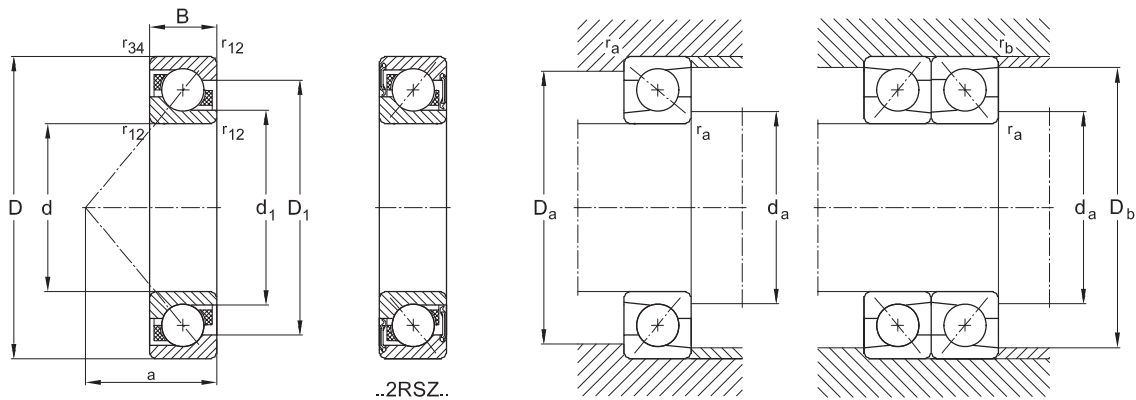

44-604

Primary dimensions			Basic designation	Basic load ratings		Fatigue load limit	Reference speed	Weight
d	D mm	B		C dyn.	C ₀ stat.			
65	120	23	7213.BE	74 000	60 500	2 300	6 400	1.000
65	140	33	7313.BE	121 000	89 500	3 650	5 900	2.150
70	125	24	7214.BE	80 000	67 500	2 550	5 900	1.100
70	150	35	7314.BE	133 500	101 000	3 900	5 400	2.650
75	130	25	7215.BE	82 000	72 000	2 650	5 900	1.200
75	160	37	7315.BE	149 000	119 000	4 150	5 400	3.200
80	140	26	7216.BE	92 000	80 000	2 800	5 600	1.400
80	170	39	7316.BE	161 000	131 000	4 500	4 800	3.700
85	150	28	7217.BE	103 500	92 000	3 300	5 100	1.800
85	180	41	7317.BE	172 500	146 000	4 900	4 800	4.300
90	160	30	7218.BE	122 000	107 000	3 700	4 800	2.200
90	190	43	7318.BE	184 000	161 000	5 300	4 300	5.000
95	170	32	7219.BE	133 500	115 000	4 400	4 600	2.600
100	180	34	7220.BE	148 500	131 000	4 400	4 300	3.200
100	215	47	7320.BE	222 000	207 000	7 000	3 700	7.200
105	190	36	7221.BE	164 500	148 000	4 800	4 100	4.200
110	200	38	7222.BE	176 000	164 500	4 900	3 700	4.500
110	240	50	7322.BE	257 500	257 500	7 200	3 400	9.300
120	215	40	7224.BE	191 000	184 000	5 300	3 400	5.300
120	260	55	7324.BE	287 500	299 000	7 700	2 700	12.400
130	230	40	7226.BE	214 000	218 500	6 100	3 200	6.200
130	280	58	7326.BE	316 000	345 000	9 000	2 700	15.200
140	250	42	7228.BE	225 500	244 000	6 500	2 700	8.600
140	300	62	7328.BE	345 000	391 000	10 000	2 400	20.500
150	270	45	7230.BE	257 500	293 000	7 000	2 400	11.000
150	320	65	7330.BE	373 500	448 500	10 500	2 200	25.000
160	290	48	7232.BE	292 000	322 000	8 500	2 300	13.500
170	310	52	7234.BE	334 000	354 000	9 300	2 100	16.000

- Bearings with brass cage M have 5% less capacity due to inner construction.
- Static capacity C₀ of hybrid bearings CB = 0.7 C₀ of bearings with steel balls.

70..BE
CB 70..BE
72..BE
CB 72..BE
73..BE
CB 73..BE

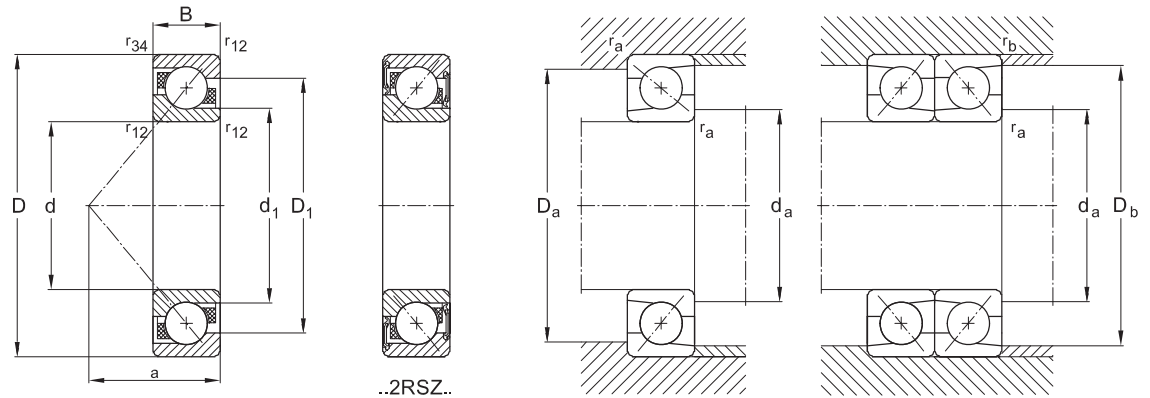

44-604

Basic designation	Dimensions					Abutment and fillet dimensions				
	a	d ₁	D ₁ mm	r ₁₂ _{min}	r ₃₄ _{min}	d _a _{min}	D _a _{max}	D _b _{max} mm	r _a _{max}	r _b _{max}
7213.BE	50	86.3	101.0	1.5	1.0	74.0	111.0	114.0	1.5	1.0
7313.BE	60	93.8	114.0	2.1	1.1	77.0	128.0	133.0	2.0	1.0
7214.BE	53	91.3	106.0	1.5	1.0	79.0	116.0	119.0	1.5	1.0
7314.BE	64	100.0	123.0	2.1	1.1	82.0	138.0	143.0	2.0	1.0
7215.BE	56	96.5	111.0	1.5	1.0	84.0	121.0	124.0	1.5	1.0
7315.BE	68	108.0	130.0	2.1	1.1	87.0	148.0	153.0	2.0	1.0
7216.BE	59	104.0	118.0	2.0	1.0	91.0	129.0	134.0	2.0	1.0
7316.BE	72	115.0	137.0	2.1	1.1	92.0	158.0	163.0	2.0	1.0
7217.BE	63	110.0	127.0	2.0	1.0	96.0	139.0	144.0	2.0	1.0
7317.BE	76	122.0	145.0	3.0	1.1	99.0	166.0	173.0	2.5	1.0
7218.BE	67	117.0	135.0	2.0	1.0	101.0	149.0	154.0	2.0	1.0
7318.BE	80	129.0	153.0	3.0	1.1	104.0	176.0	183.0	2.5	1.0
7219.BE	72	124.0	143.0	2.1	1.1	107.0	158.0	163.0	2.0	1.0
7220.BE	76	131.0	151.0	2.1	1.1	112.0	168.0	173.0	2.0	1.0
7320.BE	90	145.0	173.0	3.0	1.1	114.0	201.0	208.0	2.5	1.0
7221.BE	80	138.0	159.0	2.1	1.1	117.0	178.0	183.0	2.0	1.0
7222.BE	84	145.0	167.0	2.1	1.1	122.0	188.0	193.0	2.0	1.0
7322.BE	98	161.0	194.0	3.0	1.1	124.0	226.0	233.0	2.5	1.0
7224.BE	90	157.0	179.0	2.1	1.1	132.0	203.0	208.0	2.0	1.0
7324.BE	107	178.0	211.0	3.0	1.1	134.0	246.0	253.0	2.5	1.0
7226.BE	96	169.0	193.0	3.0	1.1	144.0	216.0	222.0	2.5	1.0
7326.BE	115	190.0	228.0	4.0	1.5	147.0	263.0	271.0	3.0	1.5
7228.BE	103	183.0	210.0	3.0	1.1	154.0	236.0	243.0	2.5	1.0
7328.BE	123	203.0	243.0	4.0	1.5	157.0	283.0	291.0	3.0	1.5
7230.BE	111	197.0	226.0	3.0	1.1	164.0	256.0	263.0	2.5	1.0
7330.BE	131	216.0	259.0	4.0	1.5	167.0	303.0	311.0	3.0	1.5
7232.BE	118	211.0	242.0	3.0	1.1	174.0	276.0	283.0	2.5	1.0
7234.BE	126	226.0	260.0	3.0	1.1	185.0	297.0	304.0	2.5	1.0

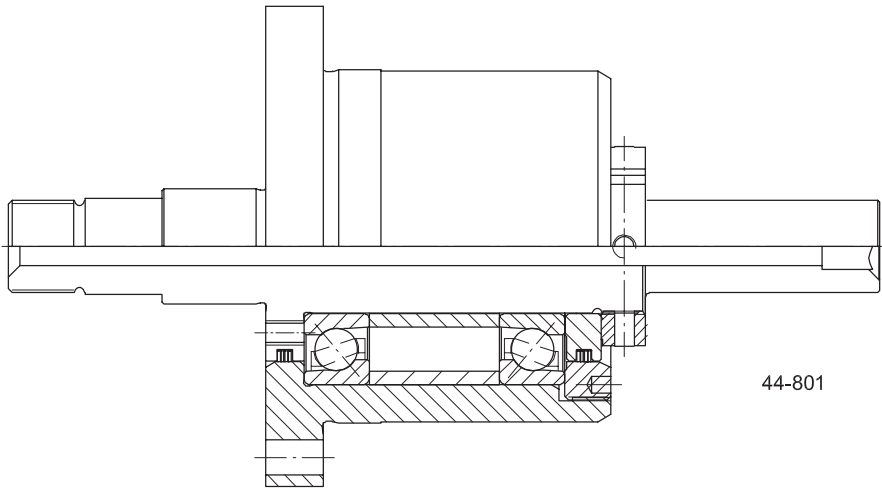

44-801

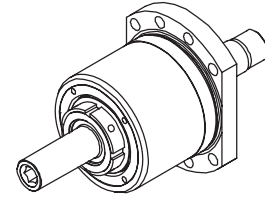

44-801a

1. Two bearings 7207.BEP.P5.U.L with two spacers of same size are used for a cutting knife support. Easy mounting is possible without any further adjustments due to ground preload. Grease lubrication rotational speed is 7000 min^{-1} . The whole set has been completely mounted and supplied by IBC, including shaft and housing. (See picture 44-801, 44-801a)

3. In case the pump shaft is driven directly by a motor axially mounted with an intermediate coupling, X-arrangement should be preferred for better compensation of alignment faults. (> See picture 44-803)

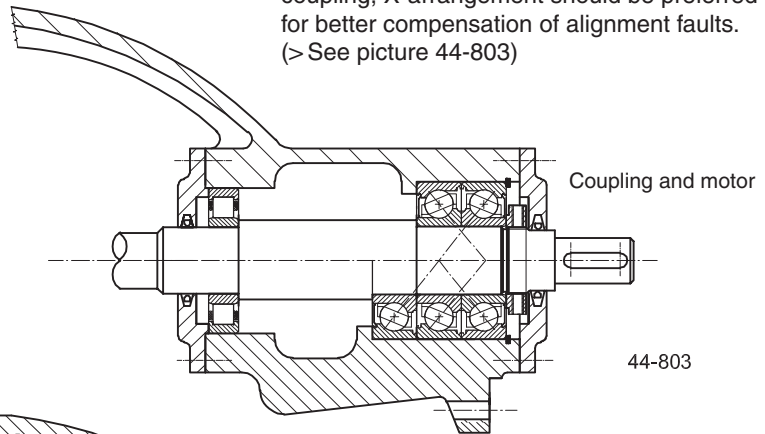

44-803

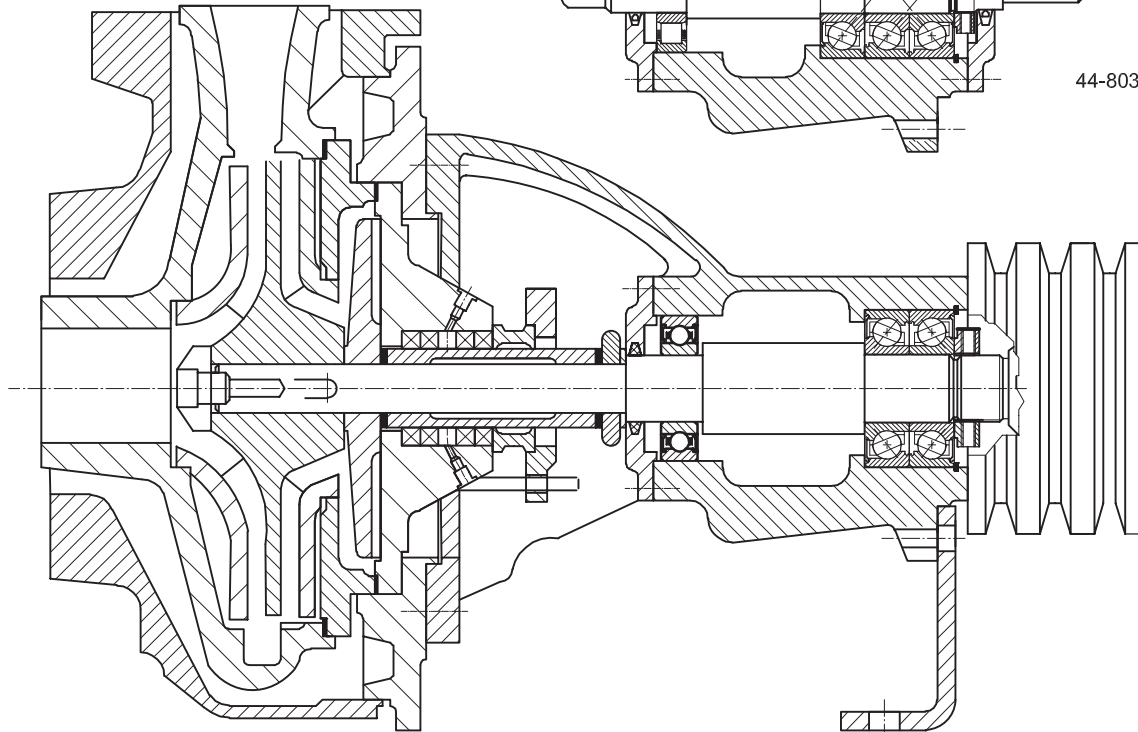

44-802

2. Bearings in O-arrangement have been built in at a belt driven pump support. The O-arrangement better bears the moment of tensile load of the V-belt. (> See picture 44-802)

(For further components like precision locknuts and labyrinth seals refer to catalogue TI-I-5000.0/E, TI-I-5010.2/E or TI-I-5020.0/E.)

More of IBC ...



Company Profile
(German)
(English)



Product Range
Super Precision Bearings
TI-I-5000.0 / D (German)
TI-I-5000.0 / E (English)

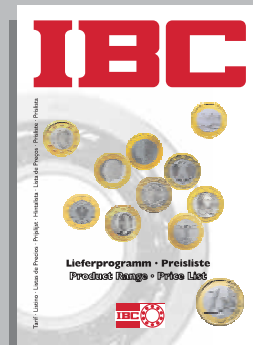

Product Range
Price List

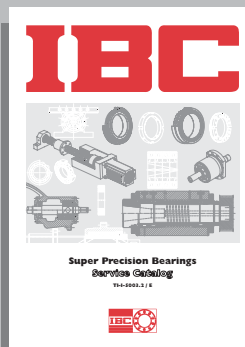

Super Precision Bearings
Service Catalog
TI-I-5003.1 / D (German)
TI-I-5003.2 / E (English)



Linear Motion Bearings
TI-I-7001.2 / D (German)
TI-I-7001.1 / E (English)



Telescopic Rails
TI-I-7005.1 / D (German)



Ball Screw Support Bearings
TI-I-5010.2 / D (German)
TI-I-5010.2 / E (English)



Precision Locknuts
TI-I-5020.0 / D (Deutsch)
TI-I-5020.0 / E (English)



ATCoated Bearings
TI-I-5010.2 / D (German)

IBC WÄLZLAGER GMBH

INDUSTRIAL BEARINGS AND COMPONENTS

Post box 1825 · 35528 WETZLAR (GERMANY)

Tel: +49/64 41/95 53-02
Fax: +49/64 41/5 30 15



Corporate office
Industriegebiet Oberbiel
D-35606 Solms-Oberbiel

e-mail: ibc@ibc-waelzlager.com

<http://www.ibc-waelzlager.com>

IBC INDUSTRIAL BEARINGS

AND COMPONENTS AG

Tel: +41/32/6 52 83 53
Fax: +41/32/6 52 83 58



Corporate office
Kapellstrasse 26
CH-2540 Grenchen

e-mail: ibc@ibcag.ch

<http://www.ibc-waelzlager.com>